

MICRO LATHE NOTES

Congratulations on your purchase of the Micro Lathe II. It should provide years of service with little maintenance. Your lathe is covered by a 2 year labor and material unconditional factory warranty.

HAPPY MACHINING!!

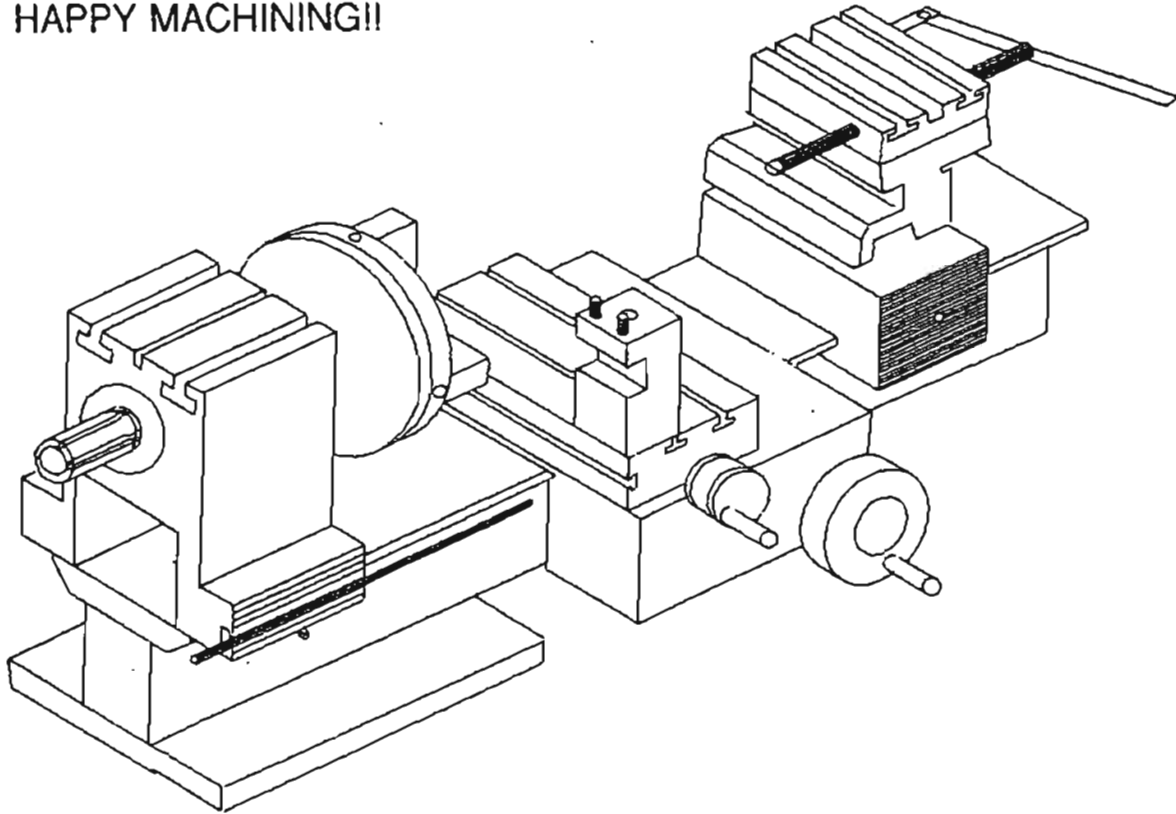

CAPACITY L 1017

Swing over bed 4 1/2" (Max. turning dia. 4 1/2")
Swing over crossslide 2 3/8" dia.
Overall length of bed 15 1/2"
Overall length of lathe 16 1/2"
Tool bit size std. 1/4"
Distance between centers 9 3/4" (tailstock optional)
Carriage travel 9"
Crossslide travel 1 3/4"

SPINDLE

Sealed precision ball 1.5748 O.D., 6692 I.D.
Spindle nose 3/4"-16 (3/4" SAE)
Spindle hole .343
Spindle I.D. taper 15 degrees (30 degrees included)
Max. collet dia. 9/32"
Pulley size 5/8" bore

TAIG TOOLS
12419 E. NIGHTINGALE LANE
CHANDLER, AZ 85286-2218

PHONE: 480-895-6978
FAX: 480-895-9648

Your Lathe

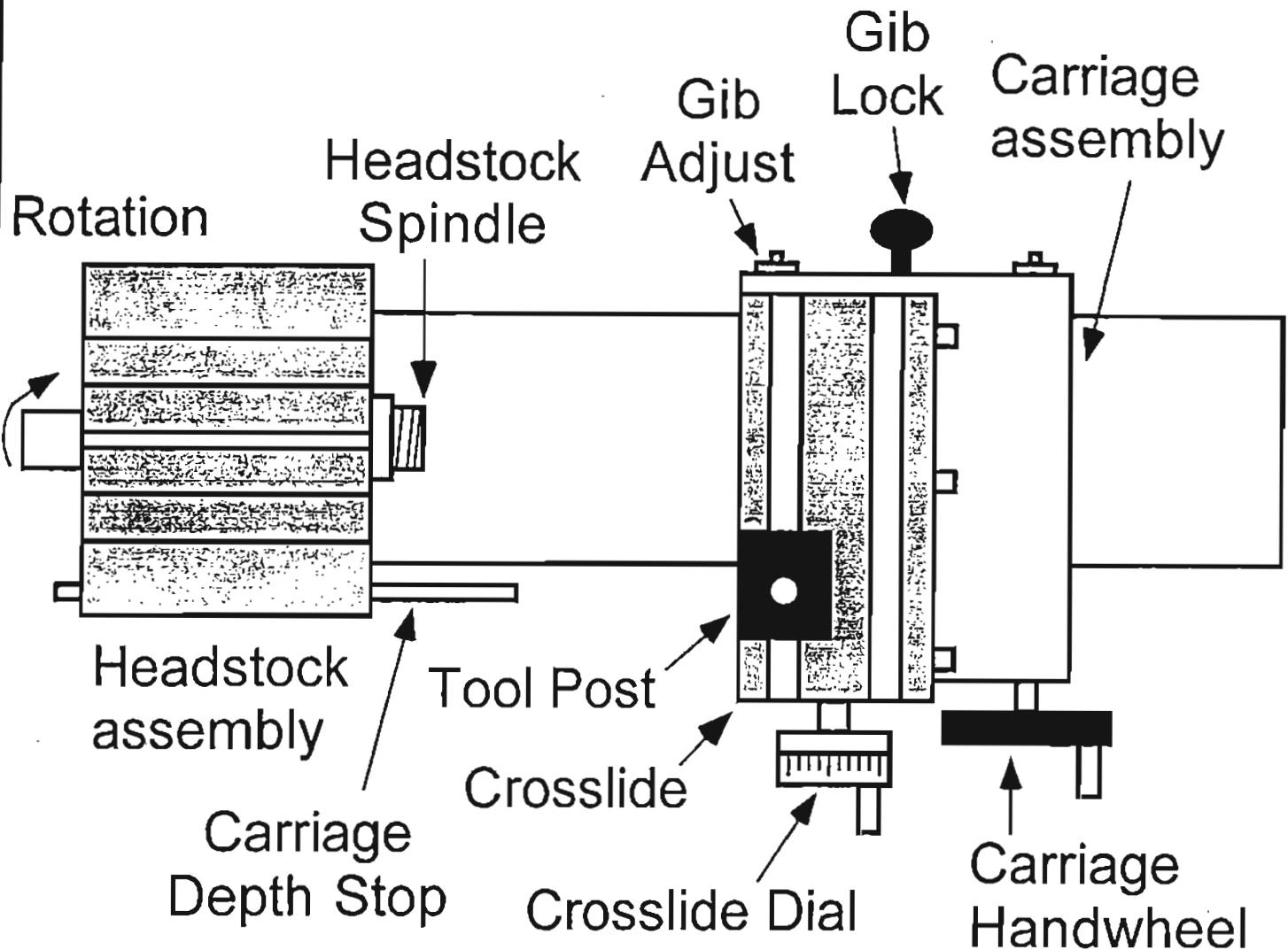

CAUTION:

- Always use SAFETY GLASSES to protect eyes from chips.
- Tighten chucks securely to avoid unscrewing during operation.
- DO NOT slow lathe with hand on pulley.
- Operate chucks in excess of middle speed with care.
- DO NOT have the belt tight as this causes the spindle to stop quickly and may cause the chuck to unscrew.

CAUTION!!

Always Wear Approved Safety Glasses when Operating Lathe. Tighten Chucks Securely to Prevent Chuck from Unscrewing. Do Not Slow Lathe by Placing Hand on Pulley. Do Not Over Tighten Belt. Keep Hands Away from Cutting Tool When Making Cuts.

The Taig Lathe is extremely well constructed and requires little maintenance. However, the lathe must be kept clean. After working a job, thoroughly clean the lathe of all debris with a soft cloth and a small brush. Make sure the spindle threads have been thoroughly cleaned and oil the bed to prevent corrosion. If the lathe is not to be used for extended periods, remove the drive belt and cover the lathe. Always check lathe components for ease of operation and lubricate as necessary. Use light oil-10 weight-such as automatic transmission fluid or in cold weather WD 40.

Loosen chucks or faceplate every few days as condensation may rust tools on spindle, especially near water or in high humidity areas.

Pulley provides six spindle speeds. Approximate spindle speed with 1750 RPM Motor is as follows:

525 Smallest motor pulley to largest lathe pulley

825

1300

2100

3350

5300 Largest motor pulley to smallest lathe pulley

The motor should sit on an angle with the weight of the motor on the belt. The motor bracket should be loose on the board to allow the motor to be raised in order to change speeds. Make sure the belt contacts properly.

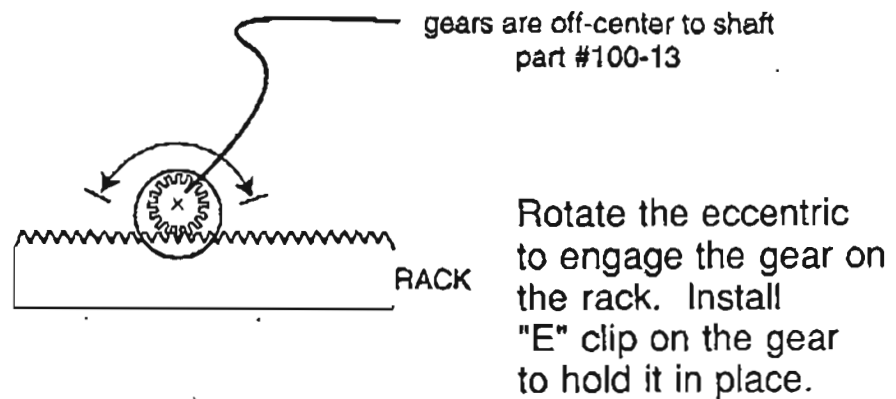
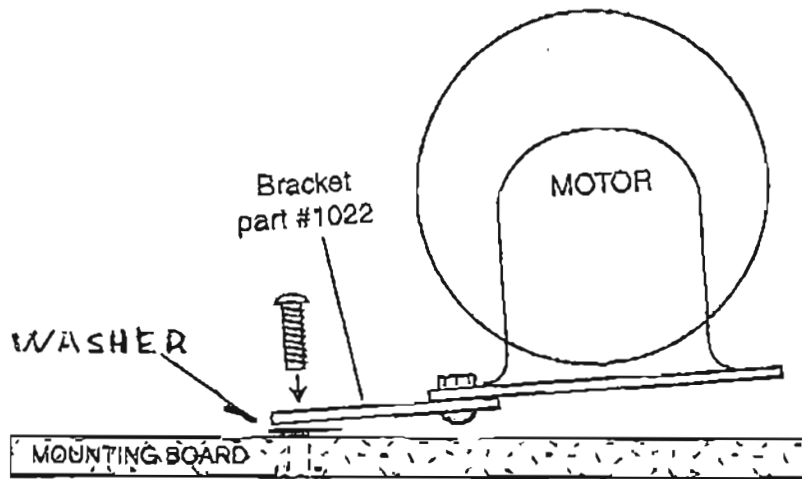

CUTTING SPEED - LATHE TURNING

Approximate values using high speed tool bits - Type M2

Work piece Diameter	Mild Steel	Brass	Alum.
1/8"	3100	6000	12000
1/4"	1550	3000	6000
1/2"	775	1500	3000
1"	387	750	1500
2"	193	375	750

A cutting fluid (coolant) should be used on all materials. This will provide longer tool life and a better finish. Water based coolants are not recommended unless lathe is cleaned thoroughly after each use. Water based coolants may cause severe corrosion on metal parts if machine is not cleaned well and re-oiled.

Carbide tipped tool bits may be used at approximately 3 times the speed of high speed tool bits.

In sharpening tool bits white or gray wheels are used for high speed tools.

Carbide tools require the use of a diamond wheel or a green (silicon carbide) wheel. Do Not cool tools by immersing in water. This may cause cracks on the carbide surface.

High speed tool bits should not change color (over heat) while sharpening. This will anneal cutting edge and shorten useful tool life.

Setting tool bits in tool post may require shimming so that cutting edge will be exactly on center. This is Very Important. One method to determine cutting edge is to machine across the face of a work piece and notice if the tool bit cutting edge is traversing across the center of the work piece. Tool bit cutting edge may be compared to the point on the tailstock.

When using steady rest slide steady rest next to the chuck and adjust the brass jaws to the work piece, then slide steady rest to the working position. This procedure allows the steady rest center to match centerline of the lathe spindle.

PART #1026 DEPTH STOP

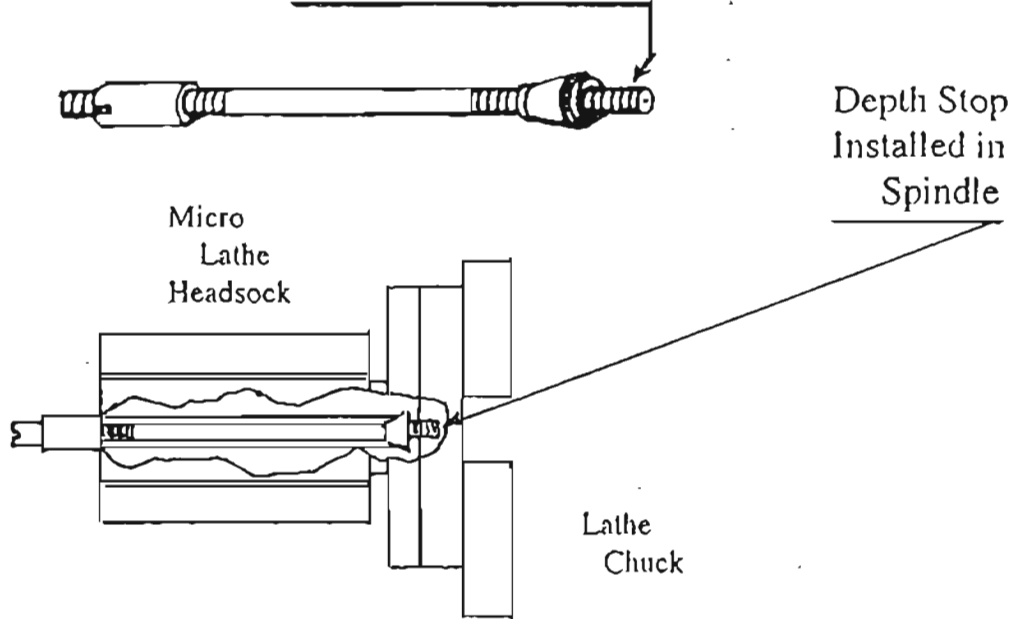

- Used to provide stop for workpiece held in chuck
- Parts held in chuck may be machined to same length

PART #1030 FOUR-JAW CHUCK

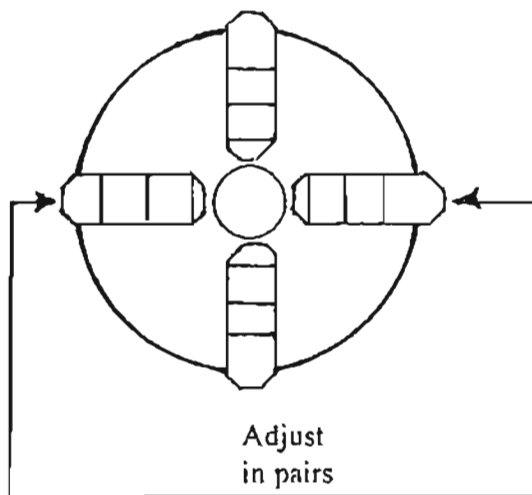

- Hardened steel with steps
Reversible range 1/8 - 3 1/4 ins.

- Jaws are independently adjusted in pairs. Four-jaw chucks are by far the most versatile of all chucks

- Parts may be machined to run very true. This will require more time to center than a three-jaw. Setting a workpiece off-center creates crankshaft and cam shapes

Your options for workpiece mounting hardware are as follows:

Part 1030: 4 Jaw Chuck

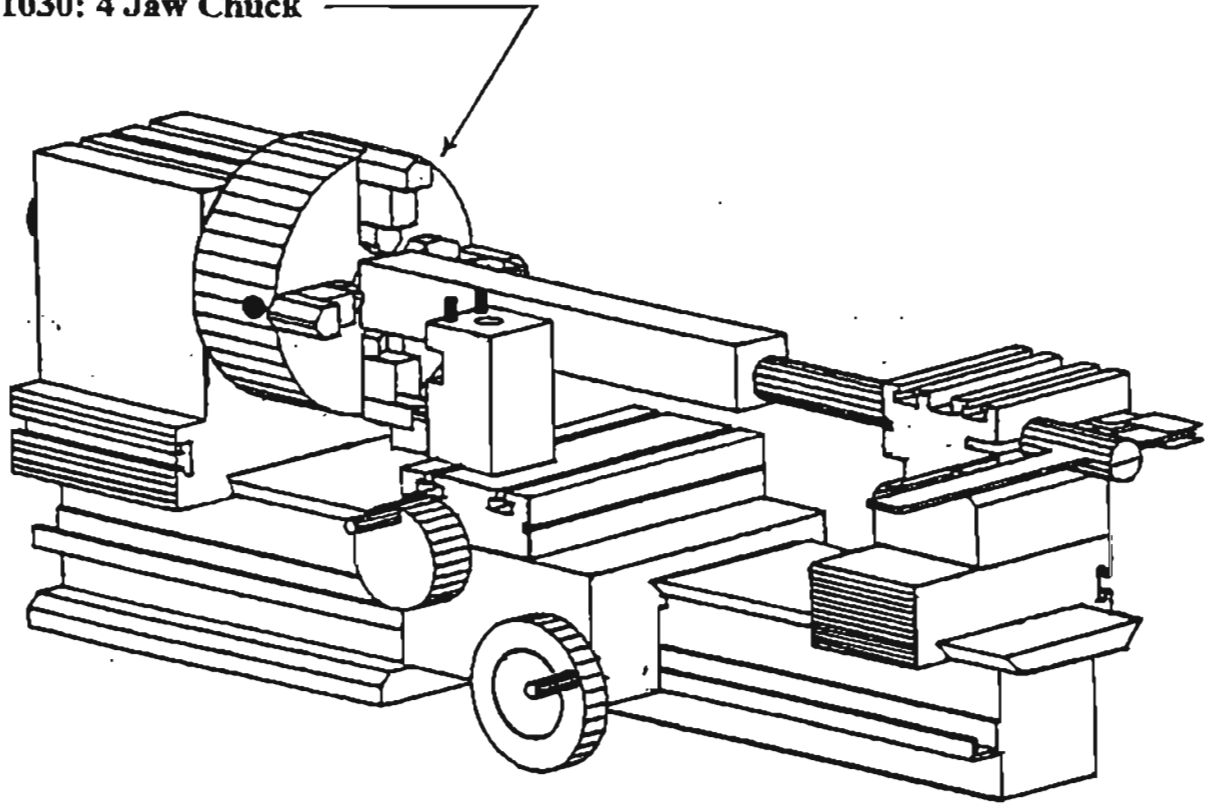

Part 1050: 3 Jaw Chuck

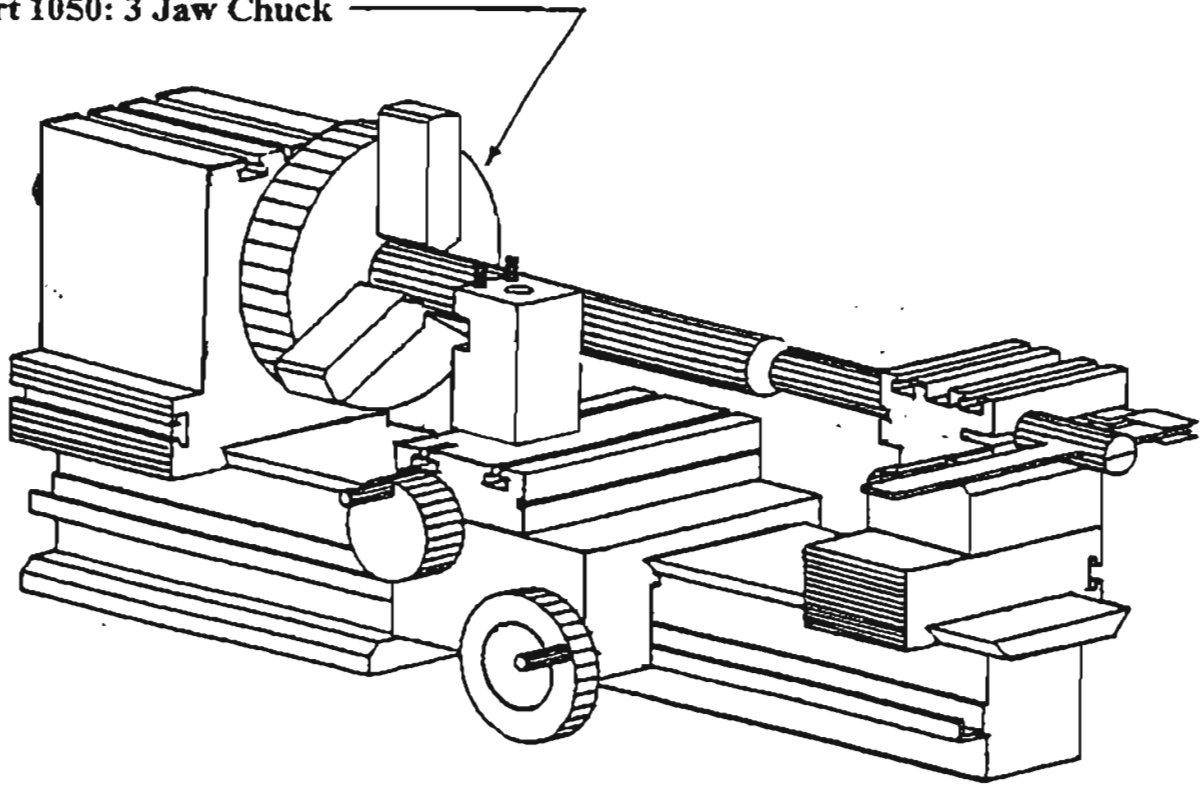

PART #1035 FACE PLATES

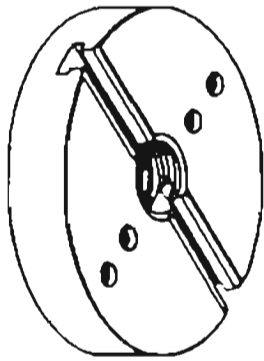

- Faceplates are used to run shafts between centers and to fixture special jobs

- Holes can be drilled and tapped if needed in faceplate

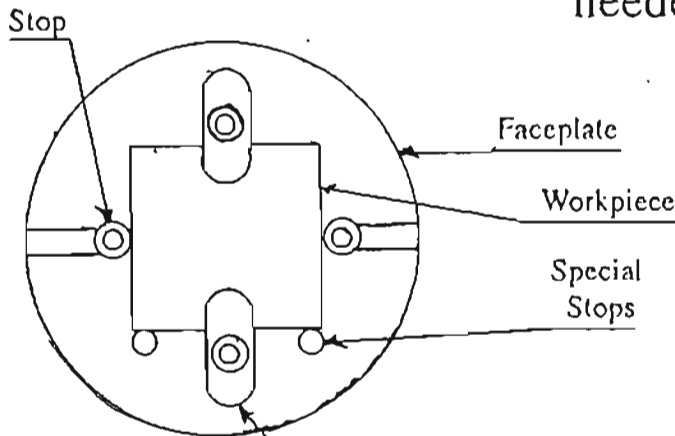

Use of Clamps

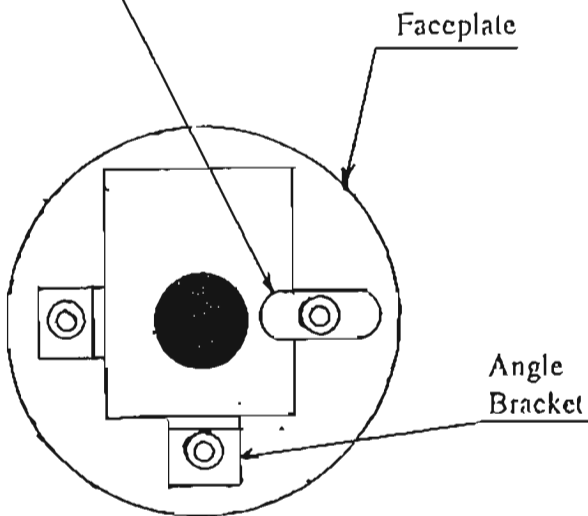

PART #1036 1 X 1 IN. SQUARE ANGLE BRACKETS (2 PIECES)

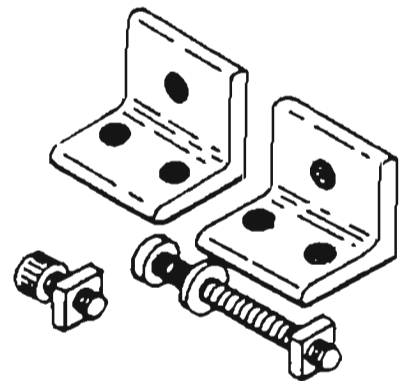

Part 1035: Faceplate
Part 1036: Angle Brackets

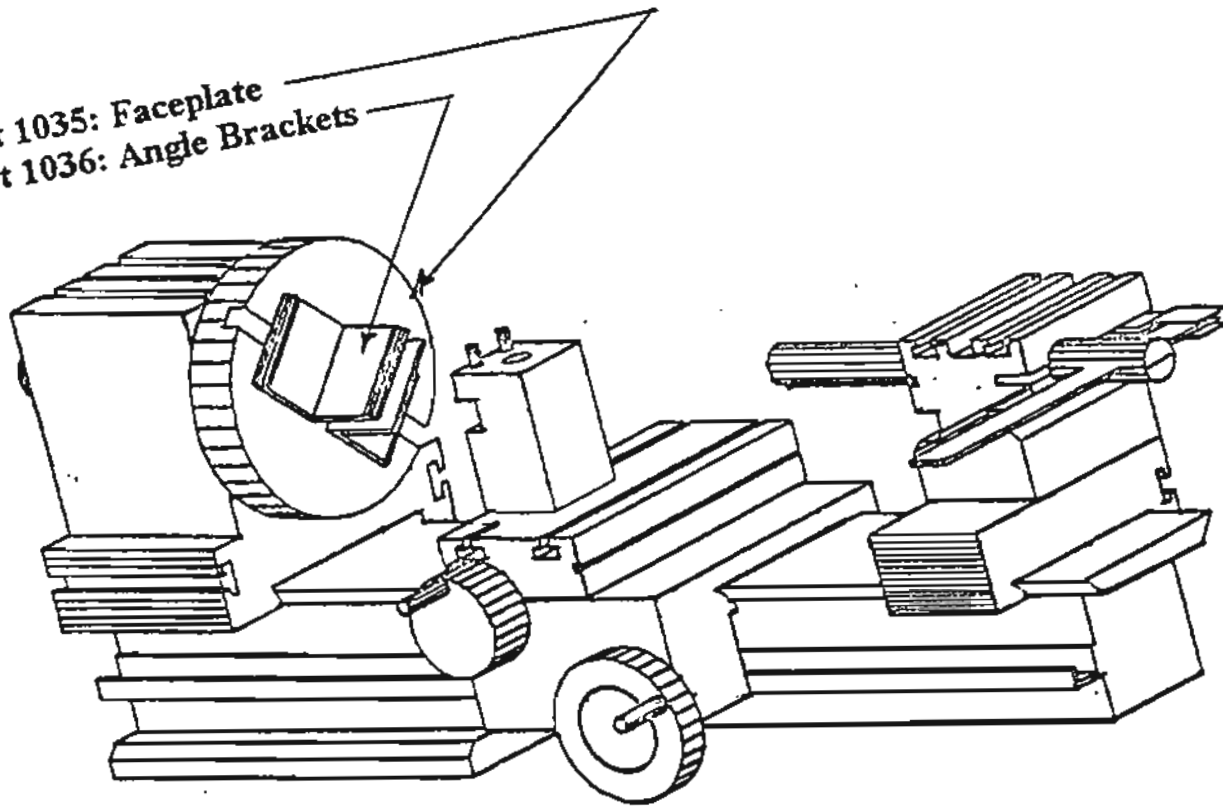

Part 1190: Steady Rest

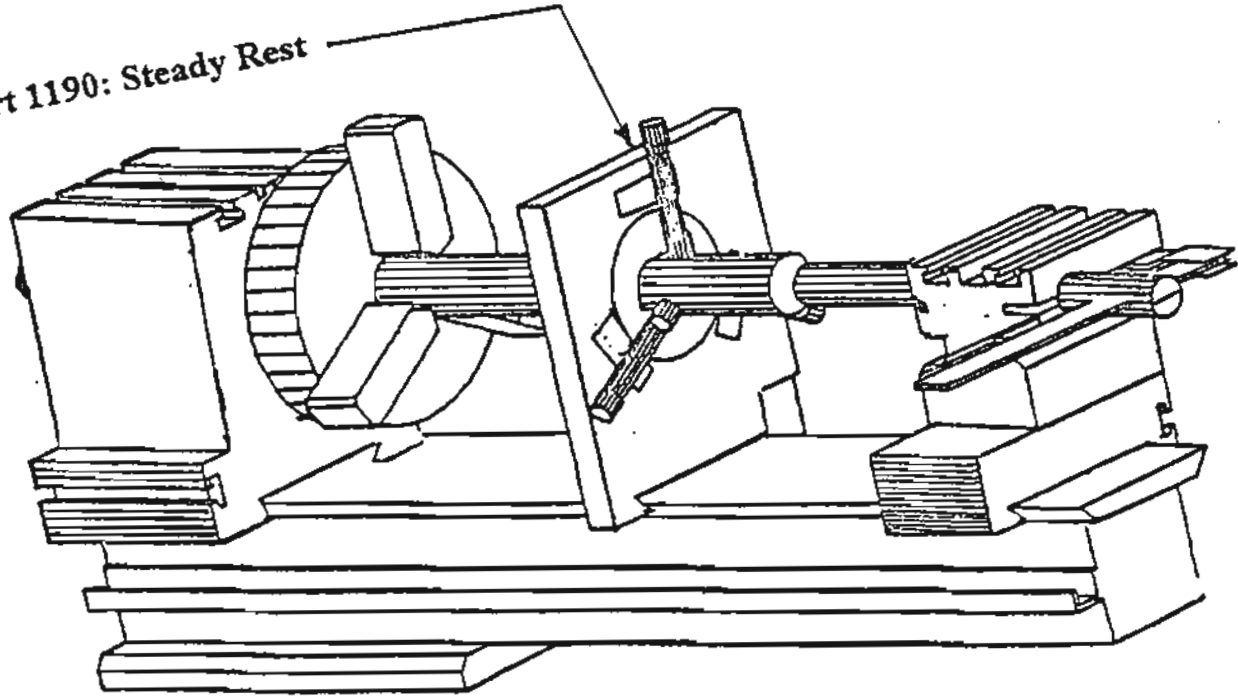

PART #1040 COLLET
PART #1042 CLOSER

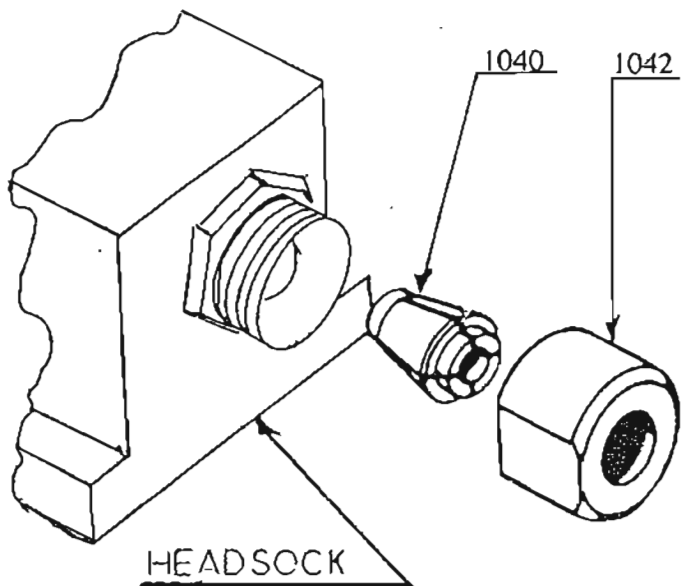

Collet is used for small diameter shaft work and holding cutters for milling. Sizes are 1/8, 5/32, 3/16, 7/32, 1/4 & 9/32 inches -- 5/16 inch is a stub collet of 3/8 inches in depth.

- Advantages of collets are they are fast and accurate and spindle may be run at maximum speed on aluminum and brass.
- Collets will accept material that is .001 over collet size to .004 under collet size. Bar stock is normally within this tolerance.

Blank Collet #1043

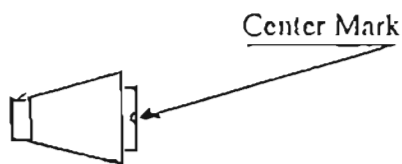

- May be used to make special sizes

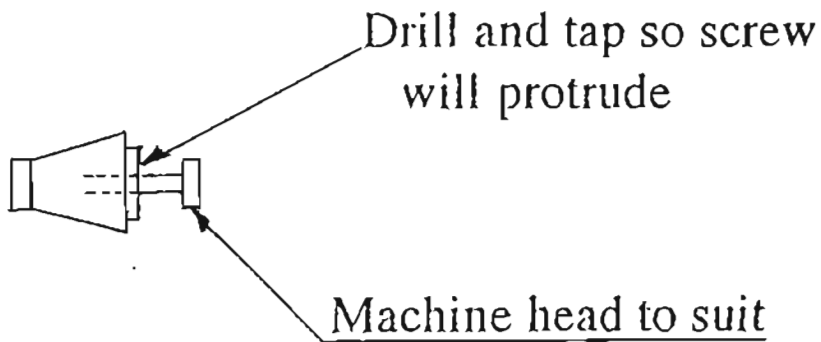

- Used to modify standard screws

Part 1052: Full Circle Jaw

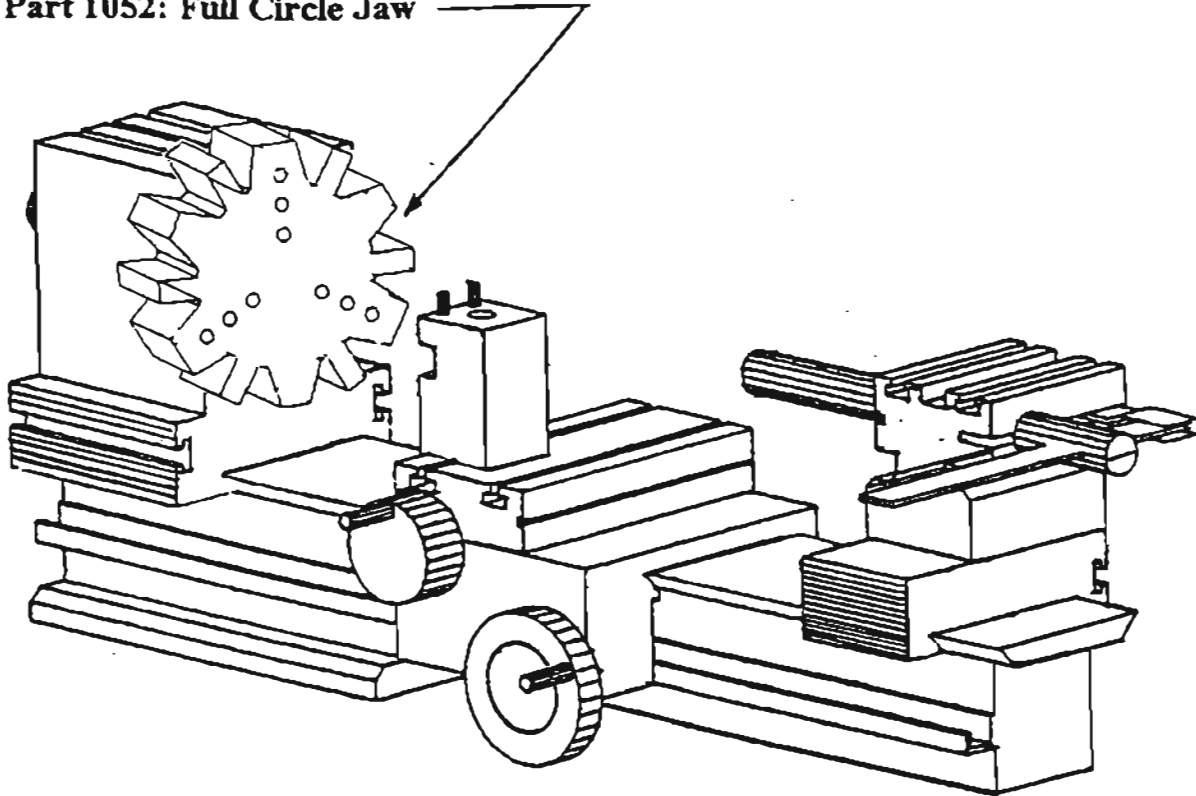

Part 1040: Collet

Part 1042: Collet Closer Nut

Part 1026: Depth Stop

Part 1043: Blank Collet

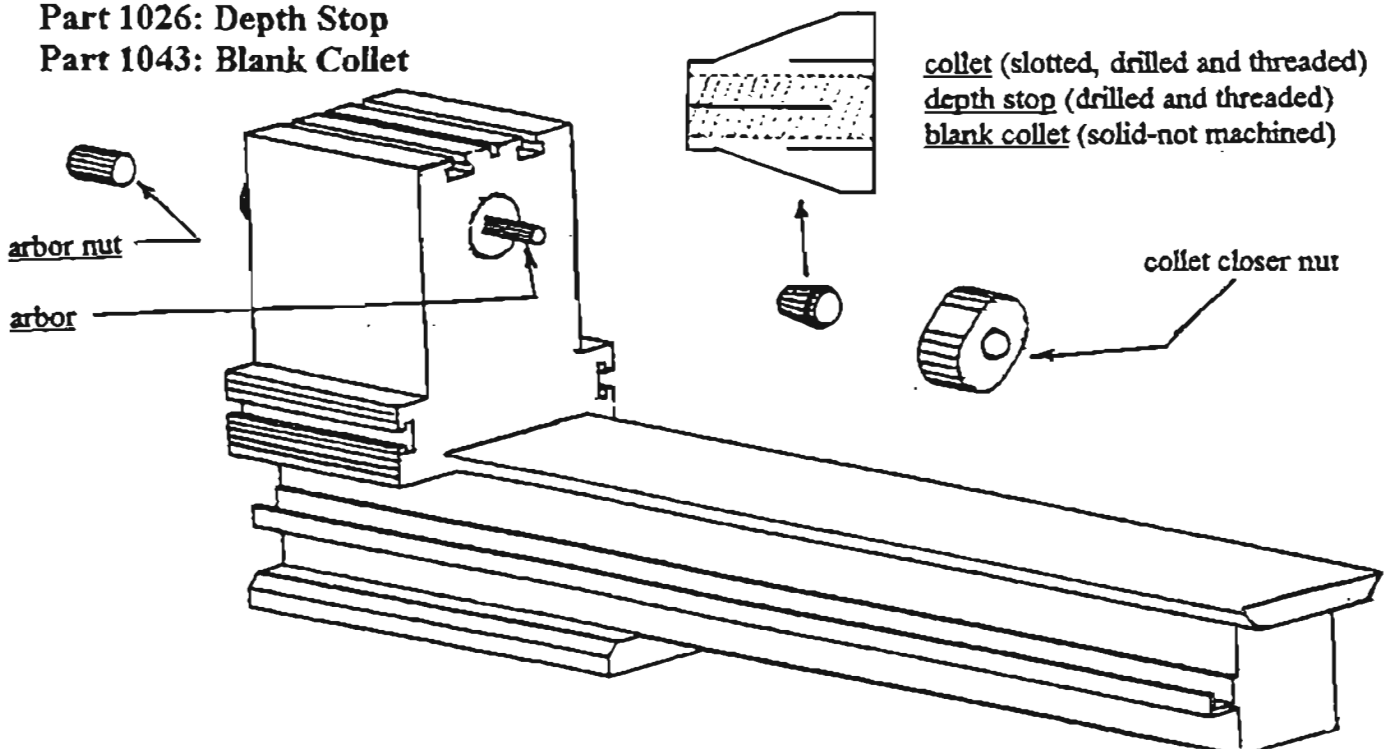

PART #1050 THREE-JAW CHUCK

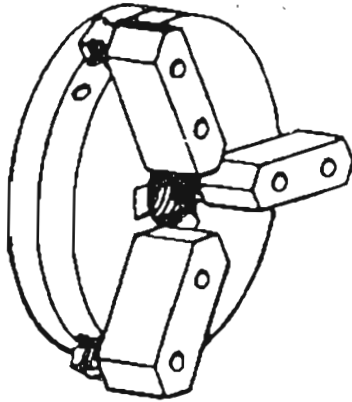

- Part #1050 is 3 1/4 inches in diameter
- All steel scroll chuck with aluminum top jaws (commonly called soft jaws)
- Three jaw chucks are used to hold round and hex material.
- The self centering ability enables all three jaws to move at the same time.

To achieve best accuracy soft jaws must be trued on spindle chuck will be used on

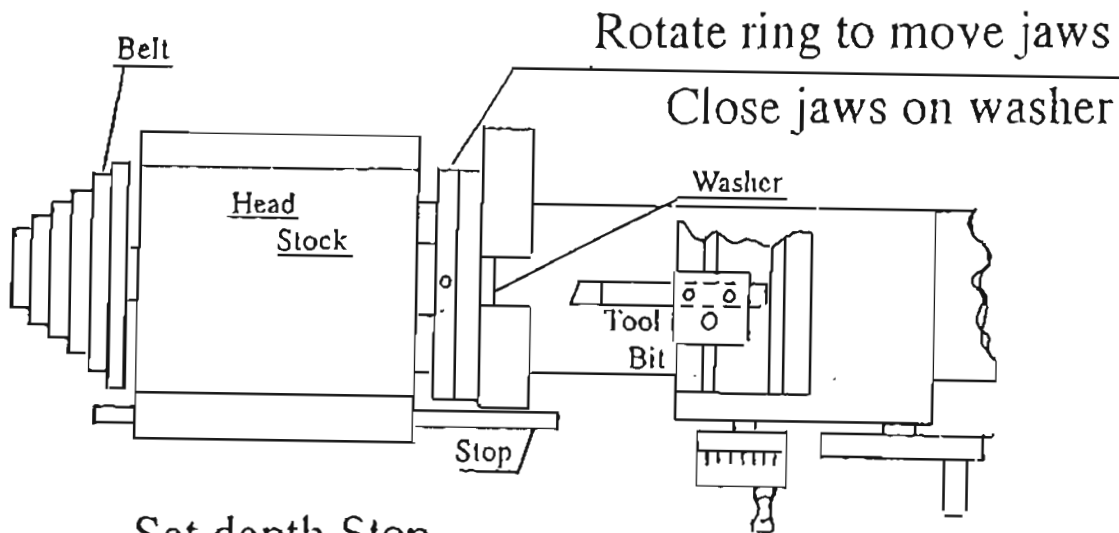

Set depth Stop rod to prevent tool bit from washer

1051 Soft Jaws

(3 pieces with 6 screws)



Spare Jaws same as supplied with chuck.

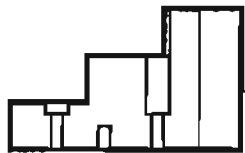
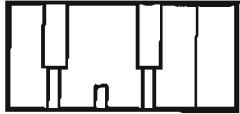

Soft Jaws may be machined with steps such as this.

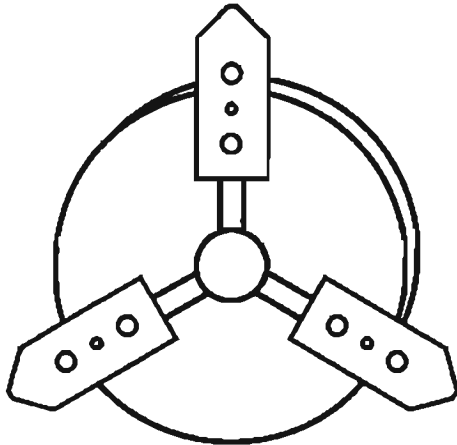

Reverse Jaws as shown to cut steps.

Advantages of Soft Jaws

1. Will not damage work piece as normal hard jaws do.
2. Greater accuracy can be obtained when machining jaws for a specific size and used on the same lathe.

Remember:

When using any chuck always mark workpiece and chuck jaws so that the part is in the same relationship if removed and replaced in chuck - A good idea is to paint one jaw with nail polish.

PART #1052 FULL CIRCLE JAW

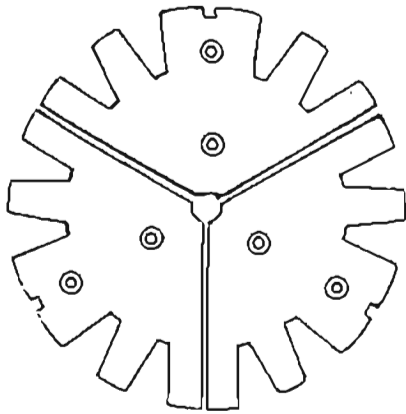

Shown with steps

- To bore jaws, place 1/4 inch diameter pin in center
- Jaws may be cut with steps to hold thin disks or clock gears
- Thin wall tubes that regular three-jaws would damage may be held by machining jaws to exact size of tube so that almost 100% contact on tube will be achieved

Part 1200: Top Slide (Compound)

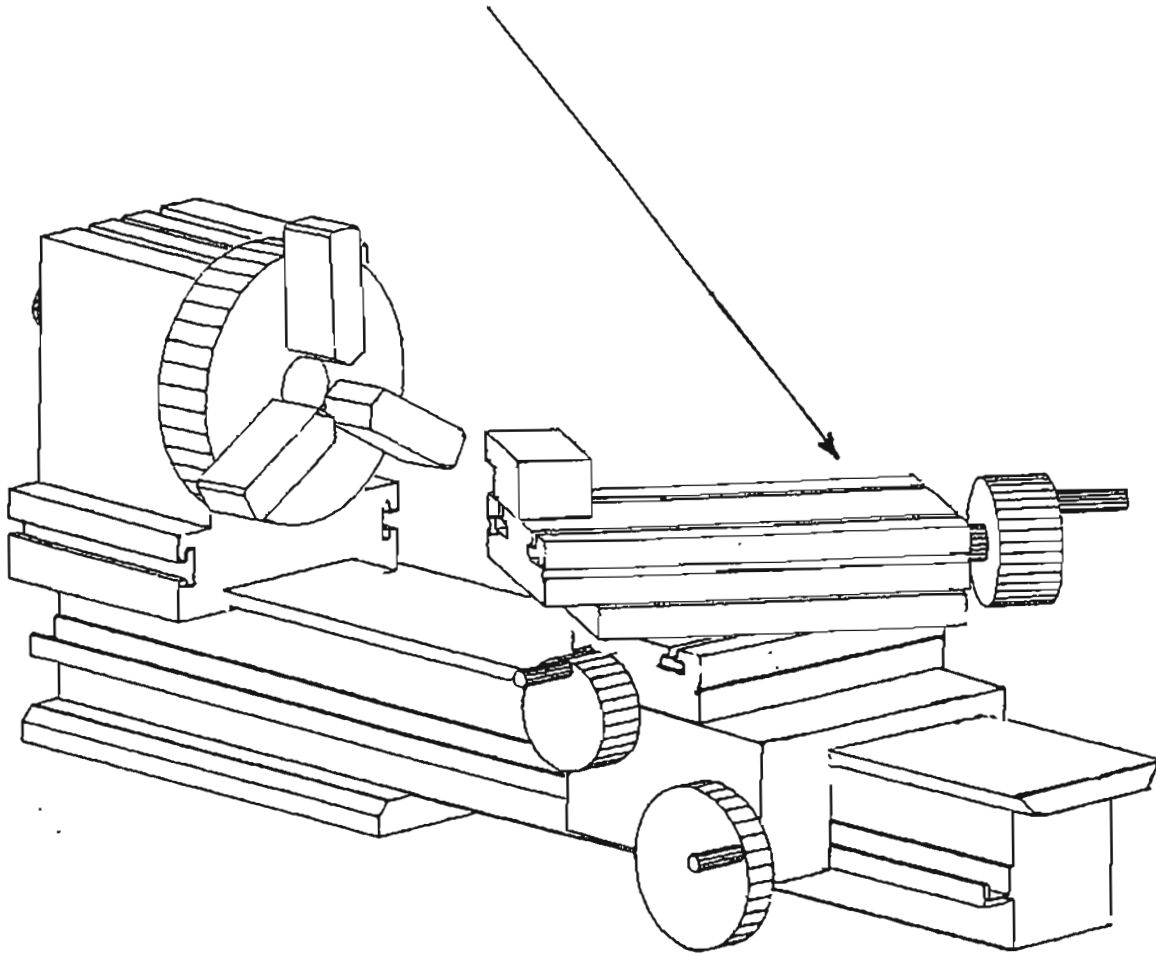

A compound is used for angles and short tapers on the work piece. The positive length may be achieved by having the compound 90 degrees to the crossslide and by using the dial on the compound to control the length of the cut.

The compound will attach to either "tee" slot of the crossslide and will rotate and be clamped at any angle. The tool bit is clamped directly on the table of the compound.

PART #1152. DIE HOLDER

• Threads may be put on a part with a button-die. This is a round piece of tool steel with thread-cutting grooves. The diameters of small button-dies are $13/16$ and 1.00 inches. In this size,

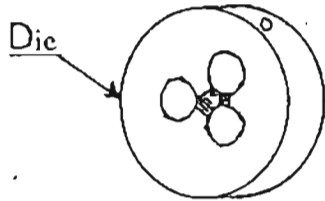

threads may be cut from 0-80 to 1/2 inch. The purpose of a die holder is to align and allow the button-die to cut a true and untapered thread. When screwing the button die on workpiece, always have a

45 degree chamfer (edge brake) on end of shaft to be threaded.

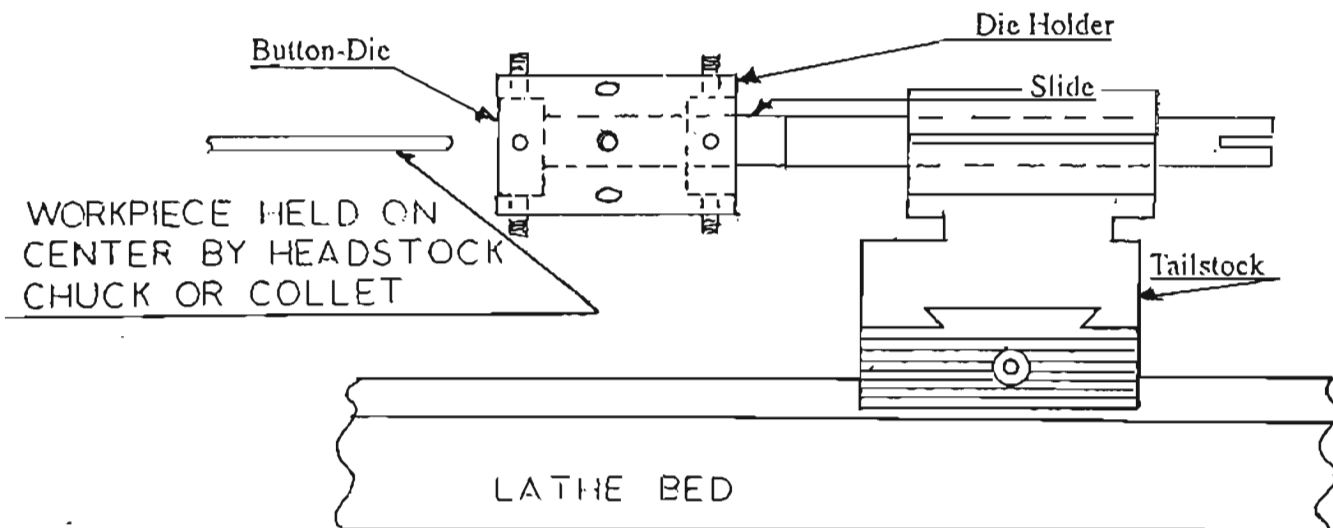

Part 1220: Milling Attachment

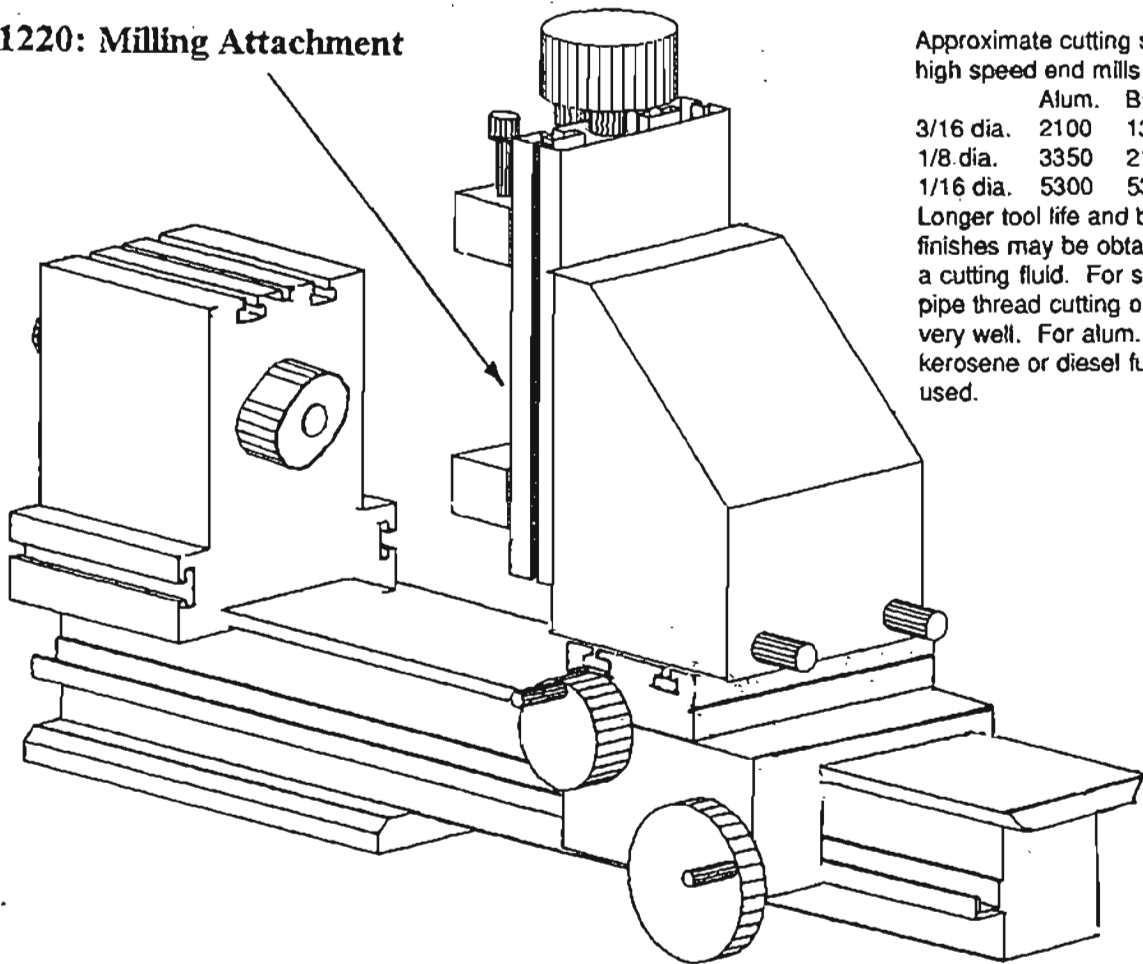

Approximate cutting speed using high speed end mills in RPM.

	Alum.	Brass	Steel
3/16 dia.	2100	1300	525
1/8 dia.	3350	2100	825
1/16 dia.	5300	5300	2100

Longer tool life and better finishes may be obtained using a cutting fluid. For steel a pipe thread cutting oil works very well. For alum. or brass kerosene or diesel fuel may be used.

The 1220 Milling Attachment provides vertical travel of approx. 1 3/4 inches. The crossslide dial provides travel in .001 increments direct reading.

The cutters (end mills) are held in the spindle with the collets to provide maximum rigidity. Miniature end mills come with 3/16 dia. bodies and various size cutting diameters. The end mills will cut all materials steel, alum., brass and plastics.

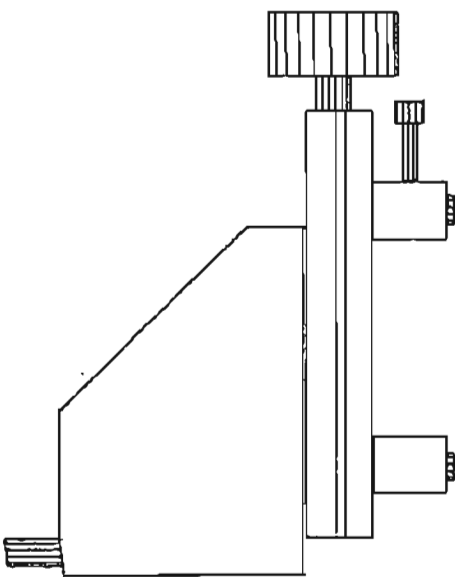

Carbide tipped router bits with 1/4 inch diameter body may be used for cutting alum., brass, plastics and wood. They are not recommended for steel. Carbide tools should run at least 4 times faster than high speed end mills of comparable size.

